

# Characterization of high density lipoprotein particles in familial apolipoprotein A-I deficiency<sup>1</sup>

Raul D. Santos,<sup>2,\*</sup> Ernst J. Schaefer,<sup>†</sup> Bela F. Asztalos,<sup>†</sup> Eliana Polisecki,<sup>†</sup> Jian Wang,<sup>§</sup> Robert A. Hegele,<sup>§</sup> Lilton R. C. Martinez,<sup>\*</sup> Marcio H. Miname,<sup>\*</sup> Carlos E. Rochitte,<sup>\*</sup> Protasio L. Da Luz,<sup>\*</sup> and Raul C. Maranhão<sup>\*</sup>

Lipid Clinic and Lipid Metabolism Laboratory,<sup>\*</sup> Heart Institute (InCor), University of Sao Paulo Medical School Hospital, Sao Paulo, Brazil; Lipid Metabolism Laboratory,<sup>†</sup> Jean Mayer United States Department of Agriculture Human Nutrition Research Center on Aging at Tufts University, and Tufts University School of Medicine, Boston, MA; and Robarts Research Institute,<sup>§</sup> London, Ontario, Canada

**Abstract** Our aim was to characterize HDL subspecies and fat-soluble vitamin levels in a kindred with familial apolipoprotein A-I (apoA-I) deficiency. Sequencing of the APOA1 gene revealed a nonsense mutation at codon -2, Q[-2]X, with two documented homozygotes, eight heterozygotes, and two normal subjects in the kindred. Homozygotes presented markedly decreased HDL cholesterol levels, undetectable plasma apoA-I, tuberoeruptive and planar xanthomas, mild corneal arcus and opacification, and severe premature coronary artery disease. In both homozygotes, analysis of HDL particles by two-dimensional gel electrophoresis revealed undetectable apoA-I, decreased amounts of small  $\alpha$ -3 migrating apoA-II particles, and only modestly decreased normal amounts of slow  $\alpha$  migrating apoA-IV- and apoE-containing HDL, while in the eight heterozygotes, there was loss of large  $\alpha$ -1 HDL particles. There were no significant decreases in plasma fat-soluble vitamin levels noted in either homozygotes or heterozygotes compared with normal control subjects. **Our data indicate that isolated apoA-I deficiency results in marked HDL deficiency with very low apoA-II  $\alpha$ -3 HDL particles, modest reductions in the separate and distinct plasma apoA-IV and apoE HDL particles, tuberoeruptive xanthomas, premature coronary atherosclerosis, and no evidence of fat malabsorption.**—Santos, R. D., E. J. Schaefer, B. F. Asztalos, E. Polisecki, J. Wang, R. A. Hegele, L. R. C. Martinez, M. H. Miname, C. E. Rochitte, P. L. Da Luz, and R. C. Maranhão. **Characterization of high density lipoprotein particles in familial apolipoprotein A-I deficiency.** *J. Lipid Res.* 2008. 49: 349–357.

**Supplementary key words** coronary heart disease • high density lipoproteins • fat soluble vitamins • xanthomas • atherosclerosis

Decreased plasma HDL cholesterol levels (<40 mg/dl in men and <50 mg/dl in women) have been associated with an increased risk of coronary heart disease (CHD) (1). Marked HDL deficiency states (HDL cholesterol < 5 mg/dl)

and undetectable plasma apolipoprotein A-I (apoA-I) levels have been reported in humans as a result of mutations at the APOA1/C3/A4 gene locus (2–18). Such patients lack apoA-I-containing HDL in plasma, with normal or decreased triglyceride levels, normal LDL cholesterol levels, and often strikingly premature CHD (2–18). Other patients with marked HDL deficiency have mutations affecting the apoA-I sequence that can affect the activity of lecithin:cholesterol acyl transferase activity (19–26). In this regard, they differ from patients with homozygous Tangier disease caused by mutations in ABCA1, who have defective cellular cholesterol efflux, detectable plasma apoA-I in pre $\beta$ -1 HDL only, hypertriglyceridemia, and decreased LDL cholesterol (27–29). Previously, defects involving the APOA1/C3/A4 gene cluster, the contiguous APOA1 and APOC3 genes, and the APOA1 gene in isolation have been described (2–26). Here, we report a kindred with isolated apoA-I deficiency, with precise lipoprotein and clinical characterization and characterization of fat-soluble vitamin levels, and document differences between this type of apoA-I deficiency and those combined with other apolipoprotein deficiencies in humans. These data provide us with important insights about the function of these apolipoproteins in human health and disease as well as about HDL particle subspecies.

## METHODS

### Kindred

The index case presented to the Lipid Clinic at the Heart Institute (InCor) of the University of Sao Paulo Hospital, Sao Paulo,

Abbreviations: apoA-I, apolipoprotein A-I; CETP, cholesteryl ester transfer protein; CHD, coronary heart disease; TRL, triglyceride-rich lipoprotein.

<sup>1</sup> Presented in part on November 14, 2006, at the Council on Arteriosclerosis, Thrombosis, and Vascular Biology sessions at the annual meeting of the American Heart Association, Chicago, IL.

<sup>2</sup> To whom correspondence should be addressed.

e-mail: raul.santos@incor.usp.br

Manuscript received 13 August 2007 and in revised form 26 September 2007 and in re-revised form 7 November 2007.

Published, JLR Papers in Press, November 8, 2007.  
DOI 10.1194/jlr.M700362-JLR200

Copyright © 2008 by the American Society for Biochemistry and Molecular Biology, Inc.

This article is available online at <http://www.jlr.org>

Brazil. He was a 39 year old male with striking tuberoeruptive xanthomas on his buttocks and lower back, and biopsy of these lesions confirmed lipid-laden macrophages. He also had palmar and planar xanthomas, as indicated by yellow creases on his palms and wrist creases, as well as corneal arcus and corneal opacification detected on slit lamp examination. Examination of his retina was normal, as was his neurological examination. On physical examination, he had blood pressure of 120/80 mmHg, height of 1.80 m, weight of 94.0 kg, body mass index of 29.0 kg/m<sup>2</sup>, and waist circumference of 105 cm. He had no evidence of hepatosplenomegaly or enlarged orange tonsils. On laboratory testing, he had normal liver, renal, and thyroid function and a normal complete blood count. His fasting glucose was 92 mg/dl. His most striking laboratory finding was an HDL cholesterol level of 4 mg/dl. He had no history of chest pain, heart disease, hypertension, diabetes, or cigarette smoking. He was asymptomatic, but on coronary stress testing he had evidence of ischemia. On coronary angiography, he had a complete obstruction of his right coronary artery and a 90% narrowing of his left anterior descending coronary artery; he underwent successful coronary artery bypass surgery.

A family tree is shown in **Fig. 1**. The proband had three children who were healthy at ages 3, 6, and 8 years, with HDL cholesterol levels of 14, 21, and 34 mg/dl, respectively. The proband's 41 year old brother had previously sustained a myocardial infarction followed by coronary artery bypass graft surgery at the age of 38 years. His brother was also noted to have tuberoeruptive

xanthomas as well as corneal arcus, and his HDL cholesterol was found to be 2 mg/dl. His daughter was in good health at age 12 years and was presumably a heterozygote, but she did not consent to having her blood drawn. Two other siblings of the index case were examined and were found not to have xanthomas, with HDL cholesterol levels of 15 and 22 mg/dl, consistent with heterozygosity. They were in good health at ages 33 and 35 years. Their children were in good health at ages 3, 8, and 10 years, with HDL cholesterol levels of 21, 45, and 42 mg/dl, respectively. The parents of the index case were alive and well at ages 65 and 66 years, with HDL cholesterol levels that were both 24 mg/dl. They were first cousins, and their fathers were nonidentical twin brothers. Therefore, the index case, his homozygous brother, and his two heterozygous siblings were products of a consanguineous marriage. Control subjects matched for the age and gender of affected family members were also selected for study. This investigation was approved by the local scientific committee and an informed consent was obtained by all participants or their parents in the case of the children.

### Biochemical measurements

Blood was collected from all subjects after an overnight fast and immediately placed on ice, and plasma was separated in a refrigerated centrifuge. Plasma cholesterol, triglyceride, HDL cholesterol, and calculated LDL cholesterol were assessed by standardized automated enzymatic methods in whole plasma

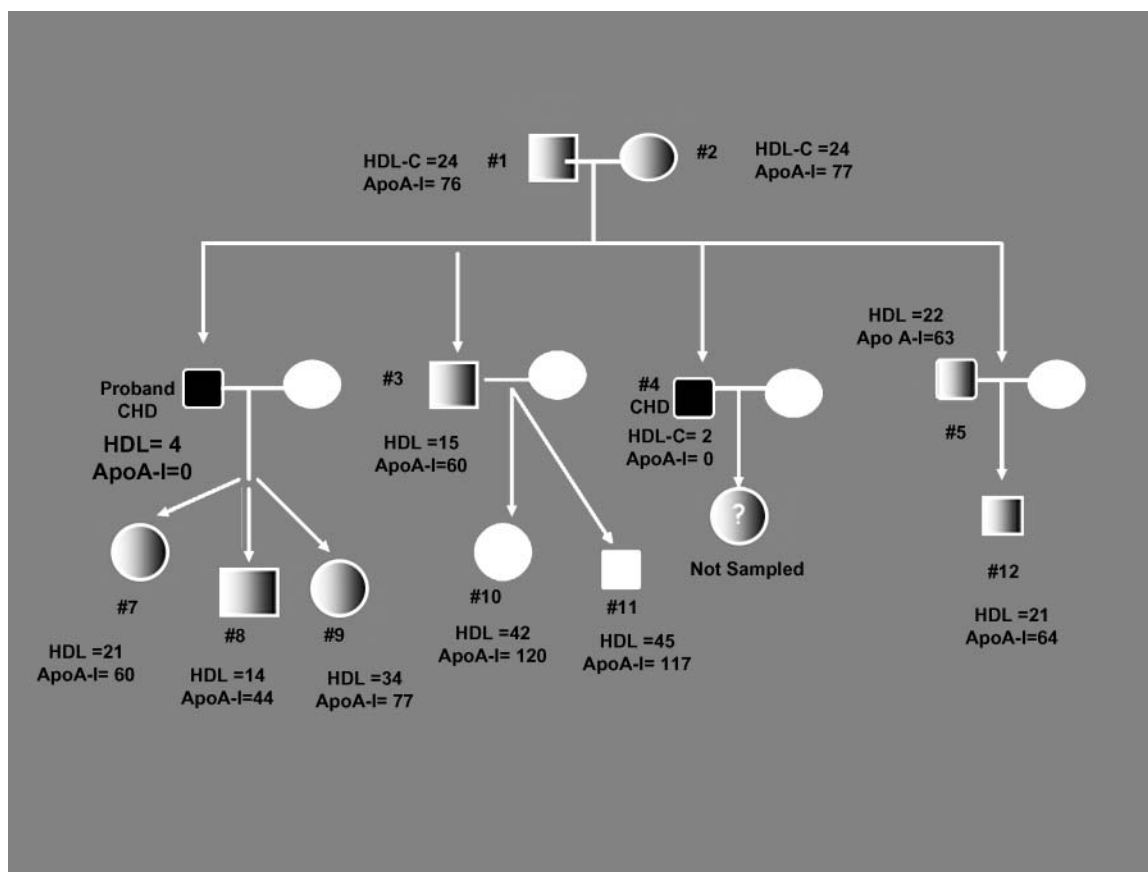

**Fig. 1.** The family tree is shown with two homozygotes (in black), two heterozygous siblings and their four heterozygous offspring (shaded), two normal offspring, as well as their two heterozygous parents (shaded), who were first cousins (their fathers were nonidentical twins). The designation of normals, heterozygotes, and homozygotes was confirmed by direct sequencing of the apolipoprotein A-I (apoA-I) gene in all individuals, except for the presumably heterozygous daughter of one of the homozygotes, who did not consent to having blood drawn.

and after precipitation of apoB-containing lipoproteins for HDL cholesterol in the clinical chemistry laboratory at the Heart Institute (InCor) of the University of Sao Paulo Hospital. All subjects had been off lipid-lowering medication for at least 2 months at the time of assessment. Plasma levels of the fat-soluble vitamins (A as retinol, D as 1,25-dihydroxyvitamin D, and E as  $\alpha$ -tocopherol) were measured by high-performance liquid chromatography at the Raul Dias dos Santos Laboratory in Sao Paulo.

Samples of plasma that had been stored at  $-80^{\circ}\text{C}$  were shipped to the Lipid Metabolism Laboratory at Tufts University in Boston, and the results of the analyses from Sao Paulo were confirmed. This laboratory also performed automated enzymatic lipid analyses, standardized by the Centers for Disease Control lipid standardization program as described previously (27–35). Free cholesterol was also assessed in whole plasma and in the HDL fraction. Plasma levels of apoA-I, apoA-II, apoB, apoC-III, and apoE were measured by immunoassay using kits obtained from Wako, Inc. (Richmond, VA), and apoA-I, apoA-II, apoA-IV, apoC-III-, and apoE-containing HDL subpopulations were assessed by two-dimensional gel electrophoresis as described previously (27–35). Absolute plasma concentrations were calculated only for apoA-I-containing particles by multiplying the plasma total apoA-I concentration (mg/dl) by the percentile value of each subpopulation. HDL subpopulations were characterized by charge (pre $\beta$ ,  $\alpha$ , pre $\alpha$ ) based on their relative mobility to albumin (first dimension), and size was determined from molecular weight standards (second dimension; see Figs. 2, 3 below). Each membrane was first probed for the apolipoprotein of primary interest, and percentage distributions of the particles were calculated. Subsequently, membranes were reprobed for apoA-I to colocalize each apolipoprotein with apoA-I and for human albumin as a reference point for the  $\alpha$ -front. One representative subject of each group was selected for illustration of the various apolipoprotein-containing HDL profiles (see Figs. 3–6 below). All lipid and apolipoprotein data reported are from the Lipid Metabolism Laboratory at Tufts University and are shown in Tables 1 and 2 below. Coefficients of variation for all assays within and between runs were  $<5\%$ .

### DNA sequencing

DNA was isolated from blood cells at InCor and shipped to Tufts University. An aliquot of DNA from the proband was then sent to Dr. Robert Hegele at the London Regional Genomics Center in Canada for sequencing of the APOA1 gene using genomic DNA. The proband was found to be homozygous for a mutation at APOA1 codon  $-2$ , namely Q $[-2]$ X, identical to a mutation in a previously reported Canadian family with apoA-I deficiency (17). This mutation results in the generation of a termination codon and the lack of any mature apoA-I being expressed in homozygotes. DNA from the proband, his homozygous brother, and all other available family members ( $n = 10$ ) were then submitted for APOA1 gene sequencing to the core sequencing facility of Tufts University School of Medicine. Molecular analysis confirmed the prior results and revealed two homozygotes, eight heterozygotes, and two normal subjects, the latter of whom were the offspring of a heterozygote and had HDL cholesterol levels of 42 and 45 mg/dl, respectively. These two subjects were included in the control group in subsequent analysis. APOE genotyping and APOE gene sequencing were suggested by Dr. Jean Davignon of Montreal, because of the proband's striking planar xanthomas. APOE genotyping in all family members revealed either the E3/3 or E4/3 genotype; moreover, the proband's APOE gene was sequenced at the core facility at Tufts University and was found to be normal.

### Data analysis

Mean values and standard deviations were calculated for all study groups. Data obtained from heterozygotes were compared with data from controls using ANOVA. A two-tailed  $P$  value of  $<0.05$  was considered statistically significant.

## RESULTS

**Table 1** shows data on plasma lipids, lipoprotein cholesterol, and apolipoproteins in controls ( $n = 10$ ), heterozygotes ( $n = 8$ ), and homozygotes ( $n = 2$ ) for this kindred with familial apoA-I deficiency. Homozygotes ( $n = 2$ ) had mean values of HDL-C, apoA-I, apoA-II, and apoE that were 6.7%, 0%, 28.9%, and 55.9% of normal, respectively; free cholesterol represented 30.2% of total cholesterol, and there was about the same percentage of HDL cholesterol as free cholesterol, ruling out LCAT deficiency. Heterozygotes had HDL cholesterol, apoA-I, and apoA-II values that were 42.6%, 46.4%, and 68.4% of control values (all  $P < 0.05$ ), with relatively normal amounts of apoB, apoC-III, and apoE in plasma.

A schematic diagram from the two-dimensional electrophoresis of normal apoA-I-containing HDL particles is shown in **Fig. 2**, and control values are provided in **Table 2**. These data are expressed both in terms of the concentration of apoA-I in the various HDL subspecies and in terms of percentages of total plasma apoA-I. In normal subjects,  $\sim 12$  mg/dl apoA-I ( $\sim 10\%$  of the total) is found in two small, discoidal pre $\beta$ -1 HDL particles, and  $\sim 22$  mg/dl ( $\sim 20\%$  of the total) is found in either large, spherical  $\alpha$ -1 HDL or in the adjacent large, spherical pre $\alpha$ -1 HDL (Figs. 2, 3). All of these HDL particles contain apoA-I without apoA-II. In contrast, intermediate-sized spherical  $\alpha$ -2 and  $\alpha$ -3 HDL contain both apoA-I and apoA-II and have a combined apoA-I concentration of  $\sim 60$  mg/dl, or  $\sim 50\%$  of the total plasma apoA-I and  $\sim 100\%$  of apoA-II in normal plasma (see Figs. 2–4). Serum amyloid A protein can also be found in  $\alpha$ -2 HDL. Adjacent to  $\alpha$ -2 and  $\alpha$ -3 HDL are the intermediate spherical pre $\alpha$ -2 and pre $\alpha$ -3 HDL, which contain apoA-I without apoA-II and together have an apoA-I concentration of  $\sim 10$  mg/dl ( $\sim 8\%$  of total plasma apoA-I). The smallest  $\alpha$  migrating HDL particles are  $\alpha$ -4 HDL and the adjacent pre $\alpha$ -4 HDL, which both

TABLE 1. Characteristics of study participants

Variable	Controls (n = 10)	Heterozygotes (n = 8)	Homozygotes (n = 2)
Male/female	7/3	5/3	2/0
Total cholesterol (mg/dl)	200 $\pm$ 38	181 $\pm$ 37	157, 174
Triglyceride (mg/dl)	117 $\pm$ 88	113 $\pm$ 45	56, 94
HDL cholesterol (mg/dl)	54 $\pm$ 13	23 $\pm$ 7 <sup>a</sup>	4.0, 3.2
LDL cholesterol (mg/dl)	126 $\pm$ 33	140 $\pm$ 33	126, 146
ApoA-I (mg/dl)	140 $\pm$ 25	65 $\pm$ 13 <sup>a</sup>	0, 0
ApoA-II (mg/dl)	38 $\pm$ 4	26 $\pm$ 5 <sup>a</sup>	10, 12
ApoB (mg/dl)	96 $\pm$ 16	97 $\pm$ 17	90, 106
ApoC-III (mg/dl)	9.1 $\pm$ 4.2	8.7 $\pm$ 3.2	3.4, 4.0
ApoE (mg/dl)	7.6 $\pm$ 3.6	4.1 $\pm$ 1.2	4.7, 3.8

ApoA-I, apolipoprotein A-I. Data are means  $\pm$  SD.

<sup>a</sup>Significantly different from controls ( $P < 0.05$ ).

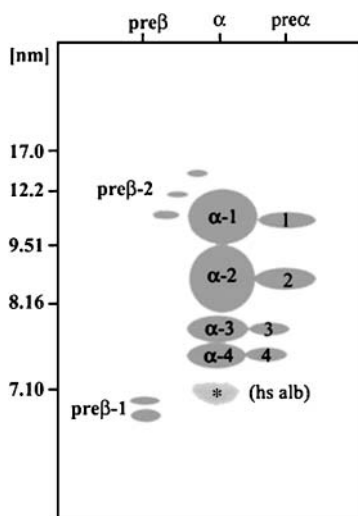

**Fig. 2.** Schematic representation of apoA-I-containing HDL subpopulations in human plasma separated by nondenaturing agarose-polyacrylamide gel electrophoresis. The nomenclature is based on HDL particle separation by electrophoretic charge relative to albumin (pre $\beta$ ,  $\alpha$ , and pre $\alpha$ ) in the first dimension and by size relative to the molecular weight standards in the second dimension. The asterisk indicates the endogenous human serum albumin marking the  $\alpha$  mobility front.

contain apoA-I without apoA-II and are discoidal particles, which together have an apoA-I concentration of  $\sim 2$  mg/dl, representing  $\sim 1.5\%$  of total plasma apoA-I. Finally, there are three large pre $\beta$ -2 HDL particles that together have an apoA-I concentration of  $\sim 2$  mg/dl, or  $\sim 1.5\%$  of the total. These particles do not contain apoA-II (Figs. 2–4).

Table 2 also summarizes data on apoA-I-containing HDL subpopulations in heterozygous subjects. Homozygotes had undetectable levels of apoA-I-containing HDL, as shown in Fig. 3. They had HDL particles in the  $\alpha$ -3 region containing apoA-II but no apoA-I (Figs. 3, 4) as well as relatively normal amounts of the separate apoA-IV- and apoE-containing HDL particles, which have slow  $\alpha$  mobility (Figs. 5, 6). ApoC-III in the homozygotes was entirely in the free form and not associated with other apolipoproteins (data not shown). Heterozygotes had markedly de-

**TABLE 2.** ApoA-I concentrations in HDL subpopulations

Variable	Controls (n = 10)	Heterozygotes (n = 8)
Pre $\beta$ -1	12.2 $\pm$ 3.2 (9.9%)	6.3 $\pm$ 2.0 <sup>a</sup> (9.8%)
Pre $\beta$ -2	1.7 $\pm$ 0.9 (1.4%)	3.8 $\pm$ 1.5 <sup>a</sup> (6.0%)
$\alpha$ -1	16.8 $\pm$ 8.9 (13.6%)	3.3 $\pm$ 2.4 <sup>a</sup> (4.8%)
$\alpha$ -2	39.3 $\pm$ 9.7 (31.8%)	24.3 $\pm$ 6.2 <sup>a</sup> (37.1%)
$\alpha$ -3	24.0 $\pm$ 5.7 (19.4%)	17.1 $\pm$ 3.5 <sup>a</sup> (26.5%)
$\alpha$ -4	13.5 $\pm$ 3.6 (10.9%)	4.1 $\pm$ 1.2 <sup>a</sup> (6.4%)
Pre $\alpha$ -1	5.3 $\pm$ 3.4 (4.3%)	0.3 $\pm$ 0.4 <sup>a</sup> (0.5%)
Pre $\alpha$ -2	6.2 $\pm$ 2.4 (5.0%)	2.8 $\pm$ 0.6 <sup>a</sup> (4.3%)
Pre $\alpha$ -3	3.5 $\pm$ 1.4 (2.8%)	2.0 $\pm$ 0.7 <sup>a</sup> (3.1%)
Pre $\alpha$ -4	1.0 $\pm$ 0.4 (0.8%)	0.8 $\pm$ 0.3 (1.2%)

Data are means (mg/dl)  $\pm$  SD, with the percentage of the total value in parentheses.

<sup>a</sup>Significantly different from controls ( $P < 0.05$ ). No values are reported for homozygotes because of undetectable plasma apoA-I levels.

creased mean apoA-I concentration in large  $\alpha$ -1 HDL (19.6% of normal), some decrease in  $\alpha$ -2 and  $\alpha$ -3 HDL (61.8% and 71.3% of normal), and a more marked decrease in  $\alpha$ -4 HDL (30.4% of normal). They also had pre $\beta$ -1 HDL values that were 51.6% of normal, but their pre $\beta$ -2 HDL levels were 2.24-fold higher than normal. Gel photographs of apoA-I, apoA-II, apoA-IV, and apoE-containing HDL in heterozygotes are shown in Figs. 3–6. As mentioned previously, heterozygotes had marked decreases in  $\alpha$ -1 and  $\alpha$ -4 HDL and a marked increase in pre $\beta$ -2 HDL, with relatively normal distributions and amounts of apoA-II, apoA-IV, and apoE-containing HDL. Both heterozygotes and homozygotes had reductions in the amounts of apoA-IV and apoE staining in HDL by  $\sim 50\%$  compared with controls (Figs. 5, 6).

Levels of fat-soluble vitamins were generally normal in this kindred in both homozygotes and heterozygotes, with mean values (standard deviation) being in the normal range for retinol at 41.3 (15.3)  $\mu$ g/ml (normal, 30–80  $\mu$ g/ml), for 1,25-hydroxyvitamin D at 36.7 (46.4) pg/ml (normal, 16–60 pg/ml), and for  $\alpha$ -tocopherol at 0.7 (0.4) mg/dl (normal, 0.5–1.8 mg/dl). In the two homozygotes, retinol was 33.9 and 37.6  $\mu$ g/ml, 1,25-dihydroxyvitamin D was 19.4 and 30.2 pg/ml, and  $\alpha$ -tocopherol was 0.4 and 1.1 mg/dl. Only  $\alpha$ -tocopherol was somewhat below the normal range in one homozygote at 0.4 mg/dl.

## DISCUSSION

Three forms of familial apoA-I deficiency have been recognized: lack of apoA-I, lack of apoA-I and apoC-III, and lack of apoA-I, apoC-III, and apoA-IV. Schaefer and colleagues (2) in January 1982 described one homozygote and multiple heterozygotes in a kindred of English origin residing in northern Alabama. The index case had no xanthomas, marked HDL deficiency, low triglyceride, normal LDL cholesterol levels, and severe premature coronary artery disease. She had no history of diabetes, smoking, or hypertension and was premenopausal. She died at the time of bypass surgery at age 43 years (2–6). At autopsy, severe diffuse coronary atherosclerosis was documented (2–4). The defect in this kindred was subsequently found to be a large deletion of the entire APOA1/C3/A4 gene cluster (5). Decreased plasma levels of the fat-soluble vitamins A, D, and E ( $< 50\%$  of normal) and a moderately prolonged prothrombin time, consistent with malabsorption of fat and fat-soluble vitamins in the homozygote, were noted (5). Heterozygotes were found to have plasma HDL cholesterol, apoA-I, apoC-III, and apoA-IV levels that were  $\sim 50\%$  of normal (5). ApoA-I gene transfection studies indicated that apoA-I was essential for HDL formation, similar to what was noted in this initial kindred (6). With molecular characterization, the family was denoted as having familial APOA1/C3/A4 deficiency (5).

In June of 1982, a second kindred with apoA-I deficiency was described by Norum and colleagues (7) in two sisters with marked HDL deficiency and planar xanthomas. They had premature CHD and underwent coronary artery by-

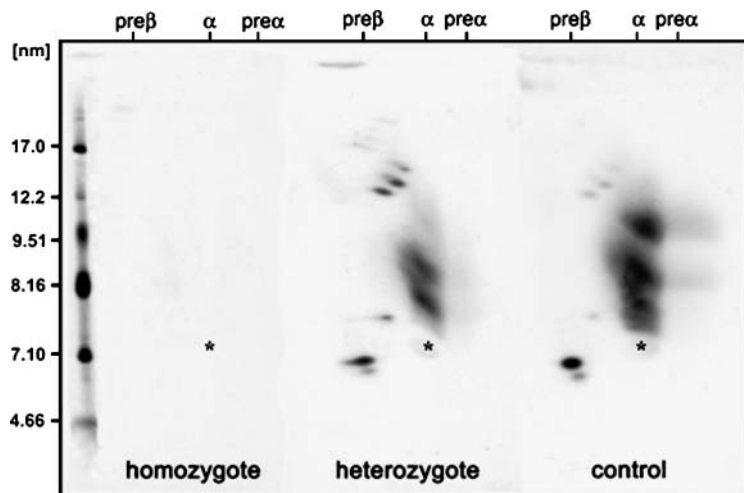
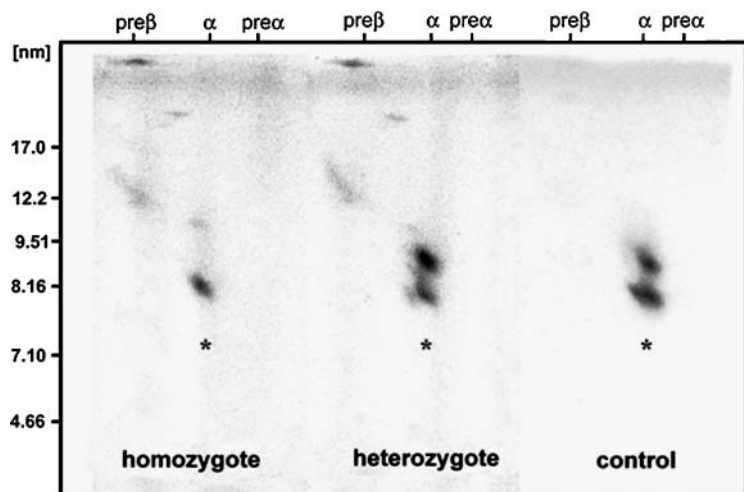

**Fig. 3.** Distribution of apoA-I-containing HDL subpopulations of a homozygote (left), a heterozygote (middle), and a normal control subject (right) separated by two-dimensional, nondenaturing agarose-PAGE. Subpopulations were characterized by charge (pre $\beta$ ,  $\alpha$ , pre $\alpha$ ) based on their relative mobility to albumin (first dimension) and by size determined from molecular weight standards [Pharmacia high molecular weight standard proteins (7.1–17.0 nm) supplemented with lactate dehydrogenase (4.66 nm)] (second dimension). The asterisk indicates the endogenous human serum albumin marking the  $\alpha$  mobility front. The images indicate undetectable apoA-I-containing HDL in the homozygote and decreases in large  $\alpha$ -1 HDL in the heterozygote. Images were virtually identical in both homozygotes and very similar in heterozygotes.

pass grafting surgery at ages 29 and 30 years. They had no history of smoking, hypertension, or diabetes, and no fat malabsorption was reported. Their triglyceride levels were reduced, and their LDL cholesterol levels were normal. The genetic defect was subsequently found to be a DNA rearrangement affecting the adjacent APOA1 and APOC3 genes, resulting in a lack of production of these two apolipoproteins and their absence from plasma (8, 9). It was also subsequently reported that these homozygotes had small amounts of apoA-II-containing HDL and enhanced clearance of very low density lipoprotein apoB, presumably because there was no apoC-III present in plasma to inhibit lipolysis (10–14). This kindred was described as having familial APOA1/C3 deficiency. A second kindred with premature CHD, marked HDL deficiency, and absence of apoA-I and apoC-III in plasma has also been described (15).

Since 1991, 10 kindreds with isolated apoA-I deficiency have been described (16–26). However, only the homozygous probands in the two kindreds described by Matsunaga et al. (16) in 1991 (codon 84 nonsense mutation) and by Ng et al. (17) in 1994 (nonsense mutation at codon –2) had undetectable plasma apoA-I levels, marked HDL defi-

ciency, and premature CHD. In the Matsunaga kindred from Japan (16), the female proband had normal triglyceride and LDL cholesterol levels and yellow-orange planar xanthomas. The APOA1 Q[–2]X mutation described in this report was first reported by Ng et al. (17, 18) in a Canadian kindred of mixed European ancestry, including Portuguese ancestry, living in Toronto. The index case was a 34 year old female who presented with marked HDL deficiency, mildly thickened Achilles tendons, xanthelasma, mild midline cerebellar ataxia, and asymmetric bilateral neurosensory hearing loss. She also had bilateral cataracts and bilateral subretinal lipid deposition with exudative proliferative retinopathy, with resultant bilateral retinal detachments requiring surgical repair. Her apoA-I levels were undetectable, and her HDL cholesterol was 2 mg/dl; her triglycerides and LDL cholesterol levels were increased. Four other homozygotes from this pedigree also had marked HDL deficiency (mean, 4 mg/dl), normal triglycerides (mean, 123 mg/dl), and increased LDL cholesterol (mean, 175 mg/dl). One homozygous sister, at age 38 years, had xanthelasma, Achilles tendon xanthomas, and planar xanthomas in the web spaces of the hands and the cubital and popliteal fossae. She had sustained a myo-



**Fig. 4.** ApoA-II-containing HDL subpopulations of a homozygote, a heterozygote, and a representative control subject showing decreased amounts of apoA-II in the  $\alpha$ -3 position only, whereas in the heterozygote and the control subjects, apoA-II is found in both the  $\alpha$ -3 and  $\alpha$ -4 positions. Images were virtually identical in both homozygotes and very similar in heterozygotes and controls. The asterisk indicates the endogenous human serum albumin marking the  $\alpha$  mobility front.

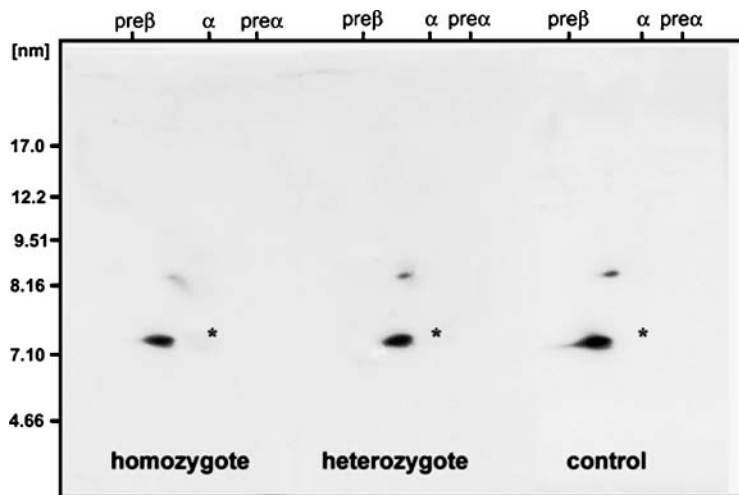

**Fig. 5.** ApoA-IV-containing HDL subpopulations of a homozygote, a heterozygote, and a control subject showing normal amounts and distribution of apoA-IV HDL in the slowly migrating  $\alpha$  position in all three subjects. Images were virtually identical in both homozygotes and very similar in heterozygotes and controls. The asterisk indicates the endogenous human serum albumin marking the  $\alpha$  mobility front.

cardial infarction at age 34 years and had coronary artery bypass grafting surgery at age 37 years. A second homozygous sister had angina and documented reversible myocardial ischemia on stress testing as well as cerebellar ataxia. The two other homozygotes, at ages 26 and 28 years, as well as four heterozygotes (ages 14–39 years) were asymptomatic and had no evidence of CHD, neuropathy, or visual impairment. In their discussion, the authors concluded that the combined hyperlipidemia in that kindred was probably not related to the APOA1 gene mutation. The findings in the present kindred would tend to support this speculation, because we observed neither combined hyperlipidemia nor Achilles tendon xanthomas. Although the Canadian kindred with APOA1 Q[–2]X did not have independently segregating classical familial hypercholesterolemia, the authors speculated that some other unmeasured defect of cholesterol metabolism resulted in the increased total and LDL cholesterol.

Other apoA-I-deficient patients reported had apoA-I present in their plasma, evidence of LCAT deficiency, no evidence of premature CHD or xanthomas, and corneal opacification (19–25). Therefore, LCAT deficiency can occur when there are mutations in the LCAT gene or in

the apoA-I gene causing the formation of abnormal apoA-I, which does not allow for the normal activation of LCAT and interferes with the activation of LCAT by other apolipoproteins.

In our APOA1 Q[–2]X kindred, in contrast to the Canadian kindred, there was no evidence of Achilles tendon xanthomas. Moreover, we did not note the combined hyperlipidemia, ataxia, cataracts, or proliferative retinopathy in our kindred, in contrast to the kindred reported by Ng and colleagues (17, 18). That pedigree, as well as our own, had consanguinity documented, raising the possibility of other homozygous mutations being present, contributing to retinal disease, ataxia, combined hyperlipidemia, and tendinous xanthomas. The common features of the two kindreds are the APOA1 Q[–2]X mutation itself, marked HDL deficiency, planar xanthomas, and premature CHD. Members of our kindred had striking tuberoeruptive xanthomas that were not observed in the kindred described by Ng and colleagues. In addition, we searched for APOE deficiency, APOE mutations, and E2/2 homozygosity but did not find these features.

These data indicate that apoA-I is essential for normal HDL formation and that its absence results in severe HDL

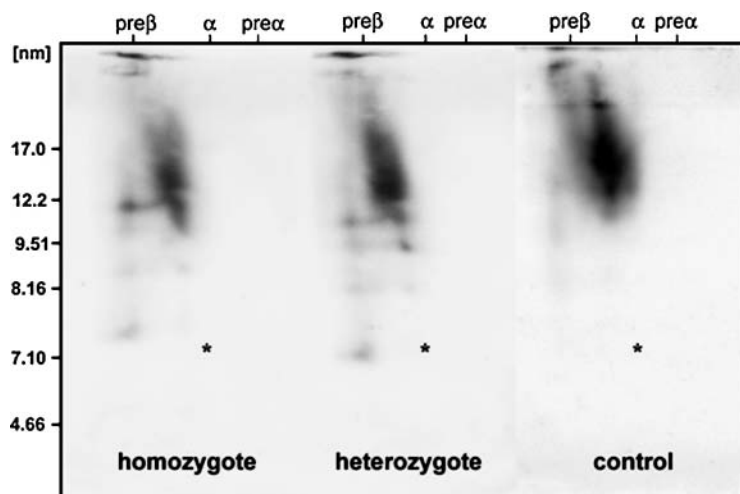

**Fig. 6.** ApoE-containing HDL subpopulations of a homozygote, a heterozygote, and a control subject showing relatively normal amounts and distribution of apoE HDL in the slowly migrating  $\alpha$  position in all three subjects. Please note that apoE HDL particles are larger than apoA-IV HDL particles. Images were virtually identical in both homozygotes and very similar in heterozygotes and controls. The asterisk indicates the endogenous human serum albumin marking the  $\alpha$  mobility front.

deficiency, xanthomas, and premature CHD. The additional presence of apoC-III deficiency as observed in APOA1/C3 deficiency results in the same phenotype, except for the presence of very low triglyceride levels, consistent with the concept that apoC-III can impair lipolysis; thus, its absence is associated with lower triglyceride concentrations. The more complex and truly polygenic APOA1/C3/A4 deficiency results in the same phenotype, except that there are no xanthomas, whereas fat malabsorption is present, consistent with the concept that apoA-IV plays a role in the intestinal absorption of fat and fat-soluble vitamins.

Research on HDL particle metabolism and function indicates that CHD patients have increases in pre $\beta$ -1 and small  $\alpha$ -4 and  $\alpha$ -3 HDL and decreases in larger  $\alpha$ -2 and  $\alpha$ -1 HDL (30–32). Moreover, it is mainly the pre $\beta$ -1 HDL that picks up free cholesterol from cells via ABCA1, and it is mainly the large  $\alpha$ -2 and  $\alpha$ -1 HDL that interacts with SRB1 in hepatocytes and other cells to promote bidirectional cholesterol flux (33). Studies in this kindred with apoA-I deficiency and in kindreds with Tangier disease indicate that the production of apoA-I is critical for HDL formation and the existence of pre $\beta$ -1 HDL, whereas the presence of normal ABCA1 function and the addition of free cholesterol and phospholipids are critical for the conversion of this particle to small discoidal  $\alpha$ -4 HDL (27–29). Studies in patients with familial LCAT deficiency indicate that cholesterol esterification via LCAT is critical for the maturation of  $\alpha$ -4 HDL to larger spherical HDL particles, and the presence of cholesteryl ester transfer protein (CETP) is critical for the formation of normal spherical  $\alpha$ -1 HDL that contain apoA-I but not apoA-II (34, 35). Surprising human subjects lacking plasma apoA-II have normal HDL levels and no evidence of premature CHD (36). In our studies in patients with homozygous CETP deficiency and lack of CHD, we noted the presence of very large spherical  $\alpha$  migrating HDL, which contain apoA-I, apoA-II, and apoE (35). It is precisely these particles that we have observed in C57BL6 mice, which naturally lack CETP (B. Asztalos, unpublished observations). Therefore, mice may not be an ideal model for human lipoprotein metabolism, and apoA-I knockout mice do not have increased atherosclerosis unless they also lack the LDL receptor (37–40).

A critical element of our data is the clear documentation of slow  $\alpha$  migrating HDL particles containing only apoE and only apoA-IV, which exist in normal plasma as well as in the plasma of patients lacking apoA-I. These particles have a distinct metabolism and probably distinct functions separate from apoA-I-containing HDL, which require further elucidation. ApoA-I is known to activate LCAT, but other apolipoproteins can also do this; therefore, in this kindred, there is no evidence of LCAT deficiency. In contrast, kindreds with apoA-I mutations affecting LCAT activity are well described, and although they have HDL deficiency, apoA-I is present in their plasma usually in excess of 10 mg/dl, and they do not appear to have premature CHD (19, 21–23, 25). ApoA-IV in HDL is clearly on its own HDL particle, and its residence time in plasma is  $\sim$ 3 days, considerably different from that of HDL apoA-I, which is  $\sim$ 5 days, and HDL apoA-II, which is  $\sim$ 5.5 days (41, 42).

Moreover, apoA-IV, like apoA-I, is a significant protein component of intestinal apoB-48-containing triglyceride-rich lipoproteins (41). ApoA-IV appears to play a role in fat absorption; hence, its absence there indicates a modest degree of malabsorption of fat and fat-soluble vitamins, not observed in this kindred with isolated apoA-I deficiency. Both apoA-I and apoA-IV proteins are transferred from triglyceride-rich lipoprotein (TRL) to HDL during TRL lipolysis, then reassociate with newly formed TRL in the extraplasmic space, and they can recycle multiple times in this manner, similar to the C and E apolipoproteins (42–45). ApoE also has its own HDL particle, and its residence time within HDL is substantially less than that of other apolipoproteins in HDL at  $\sim$ 1 day (46, 47). Only apoB-100 and apoA-I have production rates in the plasma space in humans in excess of 10 mg/kg/day, whereas apoE has a plasma production rate in humans of  $\sim$ 3.5 mg/kg/day and a somewhat lower HDL apoE production or transport rate. ApoE in TRL clearly plays a critical role in the fractional clearance of apoB-containing particles of both liver and intestinal origin, because in its absence there is a marked increase in remnant apoB-100 and apoB-48 particles with markedly delayed clearance, but HDL levels are normal (48). ApoE HDL could clearly play an important role in reverse cholesterol transport, because it can bind to hepatic LDL receptors. In humans, familial apoA-I deficiency results in much more severe and premature atherosclerosis than familial apoE deficiency, whereas the converse is true in mice, underscoring the concept that the best model for human lipoprotein metabolism remains the human, not the mouse.

The overall data in the present kindred indicate that isolated familial apoA-I deficiency results in marked HDL deficiency, xanthomas, premature CHD, and no evidence of fat or fat-soluble vitamin malabsorption. Moreover, the evidence indicates that in the absence of apoA-I, small amounts of A-II particles can be found in the  $\alpha$  migrating region of HDL at the  $\alpha$ -3 position, and levels of apoA-IV- and apoE-containing HDL are only moderately reduced and have normal electrophoretic mobility and particle size. The data also indicate that there are at least three separate and distinct types of HDL that exist in normal plasma: 1) multiple  $\alpha$ , pre $\alpha$ , and pre $\beta$ -1 particles containing apoA-I (the predominant HDL type); 2) two small- and intermediate-sized slow  $\alpha$  migrating particles containing mainly apoA-IV (a relatively minor HDL type); and 3) large slow  $\alpha$  migrating HDL containing mainly apoE (also a relatively minor HDL type). These latter two types of HDL are only moderately reduced in homozygous familial apoA-I deficiency, and their role in health and disease requires further exploration. ■

This work was supported by research grants to InCor (R.D.S.) and the Lipid Metabolism Laboratory at Tufts University from the National Institutes of Health (Grants HL-60935, HL 74753, and PO50 HL-083813) and the U.S. Department of Agriculture (Contract 53-3K06-5-10) (B.F.A., E.P., and E.J.S.) and by Genome Canada through the Ontario Genomics Institute.

## REFERENCES

- Expert Panel. 2001. Executive summary of the third report of the National Cholesterol Education Program (NCEP) Expert Panel on Detection, Evaluation, and Treatment of High Blood Cholesterol in Adults (Adult Treatment Panel III). *J. Am. Med. Assoc.* **285**: 2486–2497.
- Schaefer, E. J., W. H. Heaton, M. G. Wetzel, and H. B. Brewer, Jr. 1982. Plasma apolipoprotein A-I absence associated with marked reduction of high density lipoproteins and premature coronary artery disease. *Arteriosclerosis*. **2**: 16–26.
- Schaefer, E. J. 1984. The clinical, biochemical, and genetic features in familial disorders of high density lipoprotein deficiency. *Arteriosclerosis*. **4**: 303–322.
- Schaefer, E. J., J. M. Ordovas, S. Law, G. Ghiselli, M. L. Kashyap, L. S. Srivastava, W. H. Heaton, J. J. Albers, W. E. Connor, Y. Lemeshev, et al. 1985. Familial apolipoprotein A-I and C-III deficiency, variant II. *J. Lipid Res.* **26**: 1089–1101.
- Ordovas, J. M., D. K. Cassidy, F. Civeira, C. L. Bisgaier, and E. J. Schaefer. 1989. Familial apolipoprotein A-I, C-III, and A-IV deficiency with marked high density lipoprotein deficiency and premature atherosclerosis due to a deletion of the apolipoprotein A-I, C-III, and A-IV gene complex. *J. Biol. Chem.* **264**: 16339–16342.
- Lamon-Fava, S., J. M. Ordovas, G. Mandel, T. M. Forte, R. H. Goodman, and E. J. Schaefer. 1987. Secretion of apolipoprotein A-I in lipoprotein particles following transfection of the human apolipoprotein A-I gene into 3T3 cells. *J. Biol. Chem.* **262**: 8944–8947.
- Norum, R. A., J. B. Lakier, S. Goldstein, A. Angel, R. B. Goldberg, W. D. Block, D. K. Noffze, P. J. Dolphin, J. Edelglass, et al. 1982. Familial deficiency of apolipoproteins A-I and C-III and precocious coronary artery disease. *N. Engl. J. Med.* **306**: 1513–1519.
- Karathanasis, S. K., R. A. Norum, V. I. Zannis, and J. L. Breslow. 1983. An inherited polymorphism in the human apolipoprotein A-I gene locus related to the development of atherosclerosis. *Nature*. **301**: 718–720.
- Karathanasis, S. K., E. Ferris, and E. A. Haddad. 1987. DNA inversion within the apolipoprotein AI/CIII/AIV-encoding gene cluster of certain patients with premature atherosclerosis. *Proc. Natl. Acad. Sci. USA*. **84**: 7198–7202.
- Behr, W. T., A. Gabbard, R. A. Norum, and S. Stradnieks. 1983. Effect of blood high density lipoprotein cholesterol concentration on fecal steroid excretion in humans. *Life Sci.* **32**: 2933–2937.
- Forte, T. M., A. V. Nichols, R. M. Krauss, and R. A. Norum. 1984. Familial apolipoprotein AI and apolipoprotein CIII deficiency. Subclass distribution, composition, and morphology of lipoproteins in a disorder associated with premature atherosclerosis. *J. Clin. Invest.* **74**: 1601–1613.
- Ginsberg, H. N., N. A. Le, I. J. Goldberg, J. C. Gibson, A. Rubinstein, P. Wang-Iverson, R. Norum, and W. V. Brown. 1986. Apolipoprotein B metabolism in subjects with deficiency of apolipoproteins CIII and AI. Evidence that apoCIII inhibits catabolism of triglyceride-rich lipoproteins by lipoprotein lipase in vivo. *J. Clin. Invest.* **78**: 1287–1295.
- Subbaiah, P. V., R. A. Norum, and J. D. Bagdade. 1991. Effect of apolipoprotein activators on the specificity of lecithin:cholesterol acyltransferase: determination of cholesteryl esters formed in A-I/C-III deficiency. *J. Lipid Res.* **32**: 1601–1609.
- Bekaert, E. D., P. Alaupovic, C. S. Knight-Gibson, M. J. Laux, J. M. Pelachy, and R. A. Norum. 1991. Characterization of apoA-I and apoB containing lipoprotein particles in a variant of familial apolipoprotein A-I deficiency with planar xanthomas: the metabolic significance of LPA-II particles. *J. Lipid Res.* **32**: 1587–1599.
- Hiasa, Y., T. Maeda, and H. Mori. 1986. Deficiency of apolipoproteins A-I and C-III and severe coronary artery disease. *Clin. Cardiol.* **9**: 349–352.
- Matsunaga, T., Y. Hiasa, H. Yanagi, T. Maeda, N. Hattori, K. Yamakawa, Y. Yamanouchi, T. Tanaka, T. Obara, and H. Hamaguchi. 1991. Apolipoprotein A-I deficiency due to a codon 84 nonsense mutation of the apolipoprotein A-I gene. *Proc. Natl. Acad. Sci. USA*. **88**: 2793–2797.
- Ng, D. S., L. A. Leiter, C. Vezina, P. W. Connelly, and R. A. Hegele. 1994. Apolipoprotein A-I Q[-2]X causing isolated apolipoprotein deficiency in a family with analphalipoproteinemia. *J. Clin. Invest.* **93**: 223–229.
- Ng, D. S., P. W. O'Connor, C. B. Mortimer, L. A. Leiter, P. W. Connelly, and R. A. Hegele. 1996. Case report. Retinopathy and neuropathy associated with complete apolipoprotein A-I deficiency. *Am. J. Med. Sci.* **312**: 30–33.
- Funke, H. A., A. von Eckardstein, A. H. Pritchard, M. Karas, J. J. Albers, and G. Assmann. 1991. A frameshift mutation in the human apolipoprotein A-I gene causes high density lipoprotein deficiency, partial lecithin:cholesterol-acyl-transferase deficiency and corneal opacities. *J. Clin. Invest.* **87**: 371–376.
- Deeb, S. S., M. C. Cheung, R. Peng, A. C. Wolf, R. Stern, J. J. Albers, and R. H. Knopp. 1991. A mutation in the apolipoprotein A-I gene. *J. Biol. Chem.* **266**: 13654–13660.
- Roemling, R., A. von Eckhardstein, H. Funke, H. Motti, G. Fragiaco, G. Nosedà, and G. Assmann. 1994. A nonsense mutation in the apolipoprotein A-I gene is associated with high density lipoprotein deficiency, but not coronary artery disease. *Arterioscler. Thromb.* **14**: 1915–1922.
- Takata, K., K. Saku, T. Ohta, M. Takata, H. Bai, S. Jimi, R. Liu, H. Sato, G. Kajiyama, and K. Arakawa. 1995. A new case of apoA-I deficiency showing codon 8 nonsense mutation of the apoA-I gene without evidence of coronary artery disease. *Arterioscler. Thromb. Vasc. Biol.* **15**: 1866–1874.
- Miccoli, R., A. Bertolotto, R. Navalesi, L. Odoguardi, A. Boni, J. Wessling, H. Funke, H. Wiebusch, A. von Eckardstein, and G. Assmann. 1996. Compound heterozygosity for a structural apolipoprotein A-I variant, apoA-I (L141R) Pisa, and an apolipoprotein A-I null allele in patients with absence of HDL, corneal opacification, and coronary heart disease. *Circulation*. **94**: 1622–1628.
- Matsunaga, A., J. Sasaki, H. Han, W. Huang, M. Kugi, T. Koga, S. Ichiki, T. Shinkawa, and K. Arakawa. 1999. Compound heterozygosity for an apolipoprotein AI gene promoter mutation and a structural nonsense mutation with apolipoprotein deficiency. *Arterioscler. Thromb. Vasc. Biol.* **19**: 348–355.
- Pisciotta, L., R. Miccoli, A. Cantafora, L. Calabresi, P. Tarugi, P. Alessandrini, G. Bittolo Bon, G. Franceschini, C. Cortese, S. Calandra, et al. 2003. Recurrent mutations of the apolipoprotein A-I gene in three kindreds with severe HDL deficiency. *Atherosclerosis*. **167**: 335–345.
- Ikewaki, K., A. Matsunaga, H. Han, H. Watanabe, A. Endo, J. Tohyama, M. Kuno, J. Mogi, K. Sugimoto, N. Tada, et al. 2004. A novel two nucleotide deletion in the apolipoprotein A-I gene, apoA-I Shinbashi, associated with high density lipoprotein deficiency, corneal opacities, planar xanthomas, and premature coronary artery disease. *Atherosclerosis*. **172**: 39–45.
- Asztalos, B. F., M. E. Brousseau, J. R. McNamara, K. V. Horvath, P. S. Roheim, and E. J. Schaefer. 2001. Subpopulations of high-density lipoproteins in homozygous and heterozygous Tangier disease. *Atherosclerosis*. **156**: 217–225.
- Brousseau, M. E., E. J. Schaefer, J. Dupuis, B. Eustace, P. Van Eerdewegh, A. L. Goldkamp, L. M. Thurston, M. G. FitzGerald, D. Yasek-McKenna, G. O'Neill, et al. 2000. Novel mutations in the gene encoding ATP-binding cassette 1 in four Tangier disease kindreds. *J. Lipid Res.* **41**: 433–441.
- Brousseau, M. E., G. P. Eberhart, J. Dupuis, B. F. Asztalos, A. L. Goldkamp, E. J. Schaefer, and M. W. Freeman. 2000. Cellular cholesterol efflux in heterozygotes for Tangier disease is markedly reduced and correlates with high density lipoprotein cholesterol concentration and particle size. *J. Lipid Res.* **41**: 1125–1135.
- Asztalos, B. F., L. A. Cupples, S. Demissie, K. V. Horvath, C. E. Cox, M. C. Batista, and E. J. Schaefer. 2004. High-density lipoprotein subpopulation profile and coronary heart disease prevalence in male participants in the Framingham Offspring Study. *Arterioscler. Thromb. Vasc. Biol.* **24**: 2181–2187.
- Asztalos, B. F., D. Collins, L. A. Cupples, S. Demissie, K. V. Horvath, H. E. Bloomfield, S. J. Robins, and E. J. Schaefer. 2005. Value of high density lipoprotein (HDL) subpopulations in predicting recurrent cardiovascular events in the Veterans Affairs HDL Intervention Trial. *Arterioscler. Thromb. Vasc. Biol.* **25**: 2185–2191.
- Asztalos, B. F., M. Batista, K. V. Horvath, C. E. Cox, G. E. Dallal, J. S. Morse, G. B. Brown, and E. J. Schaefer. 2003. Change in alpha 1 HDL concentration predicts progression in coronary artery stenosis. *Arterioscler. Thromb. Vasc. Biol.* **23**: 847–852.
- Asztalos, B. F., M. de la Llera-Moya, G. E. Dallal, K. V. Horvath, E. J. Schaefer, and G. H. Rothblat. 2005. Differential effects of HDL subpopulations on cellular ABCA1 and SRB1-mediated cholesterol efflux. *J. Lipid Res.* **46**: 2246–2253.
- Asztalos, B. F., E. J. Schaefer, K. V. Horvath, S. Yamashita, M. Miller, G. Franceschini, and L. Calabresi. 2007. Role of LCAT in HDL



remodeling: investigation of LCAT deficiency states. *J. Lipid Res.* **48**: 592–599.

35. Asztalos, B. F., K. V. Horvath, K. Kajinami, C. Nartsupha, C. E. Cox, M. Batista, E. J. Schaefer, A. Inazu, and H. Mabuchi. 2004. Apolipoprotein composition of HDL in cholesteryl ester transfer protein deficiency. *J. Lipid Res.* **45**: 448–455.
36. Deeb, S. S., K. Takata, R. L. Peng, G. Kajiyama, and J. J. Albers. 1990. A splice-junction mutation responsible for apolipoprotein A-II deficiency. *Am. J. Hum. Genet.* **46**: 822–827.
37. Williamson, R., D. Lee, J. Hagaman, and N. Maeda. 1992. Marked reduction of high density lipoprotein cholesterol in mice genetically modified to lack apolipoprotein A-I. *Proc. Natl. Acad. Sci. USA.* **89**: 7134–7138.
38. Li, H., R. L. Reddick, and N. Maeda. 1993. Lack of apo A-I is not associated with increased susceptibility to atherosclerosis in mice. *Arterioscler. Thromb.* **13**: 1814–1821.
39. Plump, A. S., N. Azrolan, H. Odaka, L. Wu, X. Jiang, A. Tall, S. Eisenberg, and J. Breslow. 1997. ApoA-I knockout mice: characterization of HDL metabolism in homozygotes and identification of a post-RNA mechanism of apoA-I up-regulation in heterozygotes. *J. Lipid Res.* **38**: 1033–1047.
40. Moore, R. E., M. A. Kawashiri, K. Katajima, A. Secreto, J. S. Millar, D. Pratico, and D. J. Rader. 2003. Apolipoprotein A-I deficiency results in markedly increased atherosclerosis in mice lacking the LDL receptor. *Arterioscler. Thromb. Vasc. Biol.* **23**: 1914–1920.
41. Schaefer, E. J., L. A. Zech, L. L. Jenkins, R. A. Aamodt, T. J. Bronzert, E. A. Rubalcaba, F. T. Lindgren, and H. B. Brewer, Jr. 1982. Human apolipoprotein A-I and A-II metabolism. *J. Lipid Res.* **23**: 850–862.
42. Sun, Z., A. H. Lichtenstein, G. G. Dolnikowski, F. K. Welty, and E. J. Schaefer. 2001. Human apolipoprotein A-IV metabolism within triglyceride-rich lipoproteins and plasma. *Atherosclerosis.* **156**: 363–372.
43. Velez-Carrasco, W., A. H. Lichtenstein, P. H. R. Barrett, Z. Sun, G. G. Dolnikowski, F. K. Welty, and E. J. Schaefer. 1999. Human apolipoprotein A-I kinetics within triglyceride-rich lipoproteins and high density lipoproteins. *J. Lipid Res.* **40**: 1695–1700.
44. Schaefer, E. J., L. L. Jenkins, and H. B. Brewer, Jr. 1978. Human chylomicron apolipoprotein metabolism. *Biochem. Biophys. Res. Commun.* **80**: 405–412.
45. Schaefer, E. J., M. G. Wetzel, G. Bengtsson, R. O. Scow, H. B. Brewer, Jr., and T. Olivercrona. 1982. Transfer of human lymph chylomicron constituents to other lipoprotein density fractions during in vitro lipolysis. *J. Lipid Res.* **23**: 1259–1273.
46. Gregg, R. E., L. A. Zech, E. J. Schaefer, and H. B. Brewer, Jr. 1984. Apolipoprotein E metabolism in normolipidemic human subjects. *J. Lipid Res.* **25**: 1167–1176.
47. Cohn, J. S., R. Batal, M. Tremblay, H. Jacques, L. Veilleux, C. Rodriguez, O. Mamer, and J. Davignon. 2003. Plasma turnover of HDL apoC-I, apoC-III, and apoE in humans: in vivo evidence for a link between HDL apoC-III and apoA-I metabolism. *J. Lipid Res.* **44**: 1976–1983.
48. Schaefer, E. J., R. E. Gregg, G. Ghiselli, T. M. Forte, J. M. Ordovas, L. A. Zech, F. T. Lindgren, and H. B. Brewer, Jr. 1986. Familial apolipoprotein E deficiency. *J. Clin. Invest.* **78**: 1206–1219.